

NL200 SERIES



BENEFITS

- ▶ Continuous tuning of repetition rate while maintaining constant pulse energy, superior beam pointing and energy stability make the laser the first choice for micromachining, marking, thin film removing applications
- ▶ Close to Gaussian smooth beam profile with low value $M^2 < 1.3$ and good focusability is beneficial for such applications, as LCD and OLED display repair
- ▶ Compactness and lightness make a laser easy transportable, saves on valuable laboratory space
- ▶ Fast wavelength selection is superior for applications where alternating wavelengths are required, like material ablation, LIBS
- ▶ Air cooling, cheap and reliable end-pumping technology, amplifiers free DPSS design guarantee easy operation and alignment of laser, simple installation and low life-time ownership cost
- ▶ Variety of control interfaces USB, RS232, LAN, WLAN ensure easy control and integration of laser with laboratory or OEM equipment

NL200 series DPSS air-cooled nanosecond lasers offer high pulse energy at kHz repetition rates. End-pumped design makes this laser compact and easy to integrate into various laser equipment both industrial and R&D. Featuring short nanosecond pulse duration, variable repetition rate and external TTL triggering, nanosecond diode pumped NL200 series Q-switched lasers are excellent and cost-effective sources for specific applications, when higher pulse energy is required, like material processing, LCD and OLED

display panel repair, ablation, marking, engraving, laser cleaning, laser deposition and many more.

This laser can be equipped with harmonic generation modules for 532 nm, 355 nm, 266 nm and 213 nm wavelengths. Excellent energy stability and a wide range of wavelength options make this laser a perfect tool for spectroscopy, photoacoustic imaging and remote sensing applications. The mechanically stable and hermetically sealed design ensures reliable operation and long lifetime of the laser components.

Compact Q-switched DPSS Lasers

FEATURES

- ▶ Customers recognized reliability
- ▶ Two years warranty
- ▶ Up to 4 mJ pulse energy at 1064 nm
- ▶ Up to 2500 Hz variable repetition rate
- ▶ 532 nm, 355 nm, 266 nm, 213 nm wavelengths as standard options
- ▶ <10 ns pulse duration at 1064 nm
- ▶ Electro-optical Q-switching
- ▶ Turn-key operation
- ▶ Rugged sealed cavity
- ▶ Compact size
- ▶ Simple and robust
- ▶ Air cooled
- ▶ External TTL triggering
- ▶ Remote control via keypad and/or any controller running on any OS using REST API commands

APPLICATIONS

- ▶ Material processing
- ▶ LCD and OLED display panel repair
- ▶ Marking
- ▶ Micromachining
- ▶ Engraving
- ▶ Laser deposition
- ▶ Laser cleaning
- ▶ Ablation
- ▶ Spectroscopy
- ▶ OPO pumping
- ▶ Remote sensing

SPECIFICATIONS ¹⁾

Model ²⁾	NL201 ³⁾	NL202 ⁴⁾	NL204 ⁴⁾
Pulse energy			
at 1064 nm	0.9 mJ	2.0 mJ	4.0 mJ
at 532 nm	0.3 mJ	0.9 mJ	2.0 mJ
at 355 nm	0.2 mJ	0.6 mJ	1.3 mJ
at 266 nm	0.08 mJ	0.2 mJ	0.6 mJ
at 213 nm	0.04 mJ	0.1 mJ	0.2 mJ
Pulse to pulse energy stability (StdDev) ⁵⁾			
at 1064 nm	<0.5 %		
at 532 nm	<2.5 %		
at 355 nm	<3.5 %		
at 266 nm	<4 %		
at 213 nm	<5 %		
Typical pulse duration ⁶⁾	< 8 ns	< 10 ns	< 8 ns
Power drift ⁷⁾	± 2 %		
Pulse repetition rate	0–2500 Hz	0–1000 Hz	
Beam spatial profile	close to Gaussian in near and far fields		
Roundness	0.9–1.1 at 1064 nm		
M ²	<1.3		
Beam divergence ⁸⁾	<3 mrad		
Polarization	linear		
Typical beam diameter ⁹⁾	0.7 mm		
Beam pointing stability (RMS) ¹⁰⁾	≤10 μrad		
Optical jitter (StdDev) ¹¹⁾	<0.5 ns		

PHYSICAL CHARACTERISTICS

Laser head (W × L × H) ¹²⁾	164 × 320 × 93 mm
Power supply unit (W × L × H)	470 × 390 × 140 mm
Umbilical length	3 m

OPERATING REQUIREMENTS

Cooling	air cooled
Ambient temperature	18–30 °C
Relative humidity	20–80 % (non-condensing)
Power requirements	100–240 V AC, single phase, 50/60 Hz
Power consumption	<600 W
Cleanliness of the room	not worse than ISO Class 9

¹⁾ Due to continuous improvement, all specifications are subject to change. Parameters marked typical are illustrative; they are indications of typical performance and will vary with each unit we manufacture. Unless stated otherwise all specifications are measured at 1064 nm and maximal pulse repetition rate and for basic system without options.

²⁾ Please indicate clearly if 1064 nm output is required in case harmonics options are ordered (except H200STHC module). In such a case, the energy of 1064 nm is optimized for harmonics generation and may differ from specified in the table.

³⁾ Unless stated otherwise all specifications are measured at 2500 Hz pulse repetition rate.

⁴⁾ Unless stated otherwise all specifications are measured at 1000 Hz pulse repetition rate.

⁵⁾ Averaged from pulses emitted during 30 sec time interval.

⁶⁾ FWHM at 1064 nm.

⁷⁾ Measured over 8 hours period after 20 min warm-up when ambient temperature variation is less than ± 2 °C and humidity < ± 5%.

⁸⁾ Full angle measured at the 1/e² level at 1064 nm.

⁹⁾ Beam diameter is measured at 1064 nm at the 1/e² level.

¹⁰⁾ Beam pointing stability is evaluated as movement of the beam centroid in the focal plane of a focusing element.

¹¹⁾ With respect to QSW IN or SYNC OUT pulse.

¹²⁾ Without optional harmonic module.



PERFORMANCE

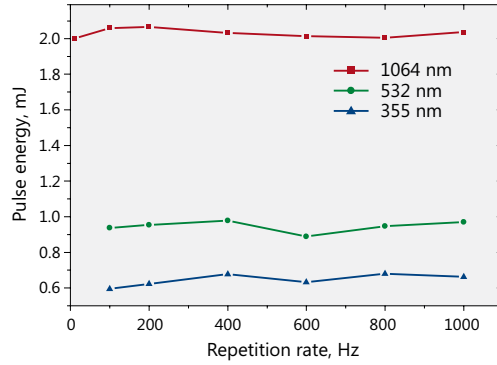

Fig 1. Typical performance data of model NL202 laser

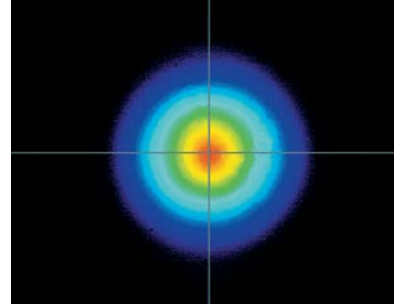

Fig 2. Typical beam intensity profile in the far field

OUTLINE DRAWINGS

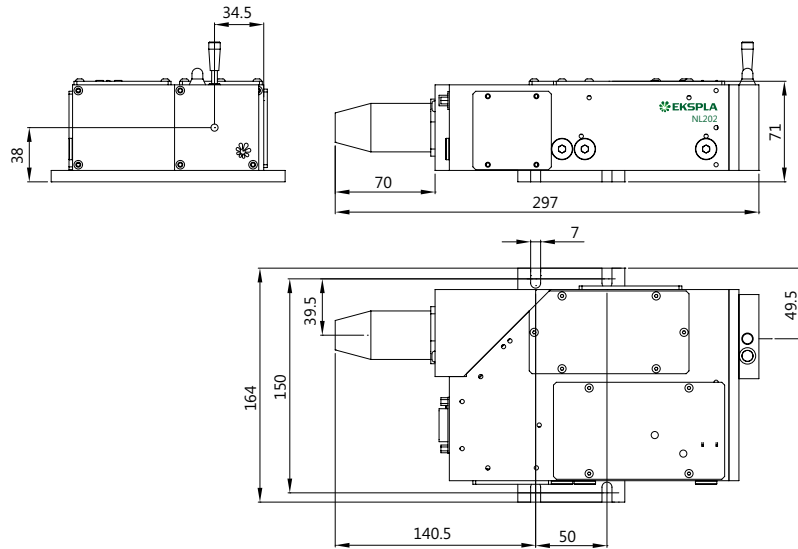

Fig 3. NL202 laser head drawing

ORDERING INFORMATION

Note: Laser must be connected to the mains electricity all the time. If there will be no mains electricity for longer than 1 hour then laser (system) needs warm up for a few hours before switching on.

NL201-H200SHC

Model	Harmonic generator options:
	H200SHC → second harmonic
	H200THC → third harmonic
	H200FHC → fourth harmonic