

LightWire FPS series

Compact
Fiber Seeders for
Picosecond Lasers



FEATURES

- ▶ Pulse energy >50 nJ at repetition rate <1 MHz
- ▶ **Sub-10 ps** pulse duration
- ▶ Close to Fourier-transform limited spectral bandwidth
- ▶ Integrated fiber pulse picker for flexible repetition rate control (25 kHz – 50 MHz, burst mode available)
- ▶ PLL option (please inquire sales@ekspla.com)
- ▶ Other wavelengths available on request

APPLICATIONS

- ▶ Seeding solid state amplifiers

LightWire FPS series fiber lasers are dedicated for seeding solid state Nd:YAG amplifiers. Compact, cost efficient FPS series models deliver sub-10 ps pulses at 1064 nm wavelength with the average output power up to 200 mW and pulse

energy up to 50 nJ. They feature narrow close to bandwidth limited spectrum and low pulse amplitude noise. Wavelength tunability ensures that seed pulses are always spectrally overlapped with the amplification spectrum of laser amplifier.

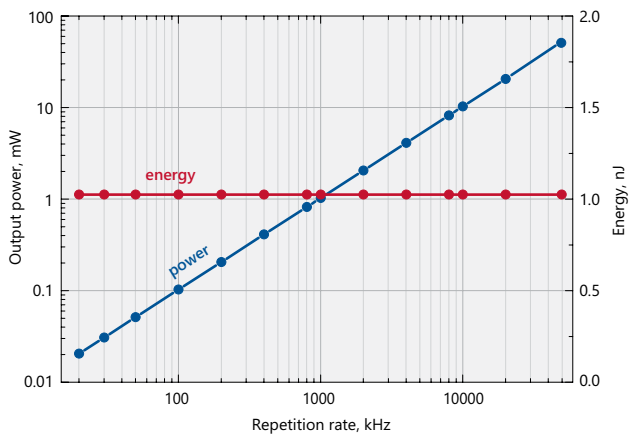

Typical dependence of average power (blue curve) and pulse energy (red curve) on the repetition rate for FPS100-AOM laser

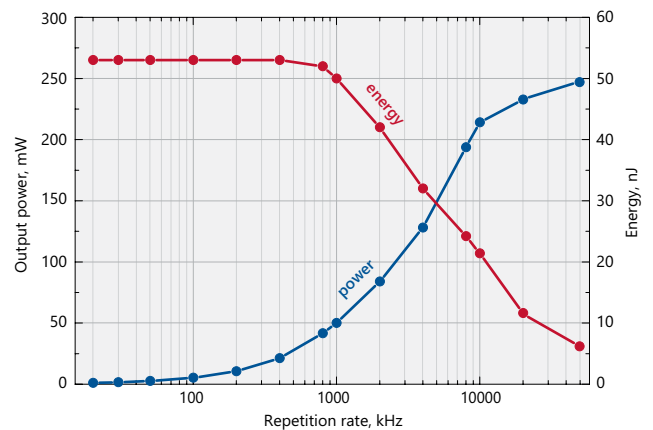

Typical dependence of average power (blue curve) and pulse energy (red curve) on the repetition rate for FPS200 laser

SPECIFICATIONS ¹⁾

Model	FPS100	FPS200
Central wavelength ²⁾	1064 nm; tunable ± 0.2 nm	
Pulse duration	7 ± 1 ps	10 ± 1 ps
Spectral bandwidth ³⁾	0.4 ± 0.1 nm	0.25 ± 0.05 nm
Oscillator pulse repetition rate ⁴⁾	50 ± 2 MHz	
Pulse repetition rate with pulse picker ⁵⁾	25 kHz – 50 MHz (PRR = PRR _{osc} / N, N = 1, 4, 5, ..., 2000)	
Output power (without/with pulse picker)	> 80 mW / > 40 mW	> 200 mW at 50 MHz > 40 mW at 1 MHz > 5 mW at 100 kHz
Pulse energy (without/with pulse picker)	> 1.6 nJ / > 0.8 nJ	> 50 nJ at repetition rates < 200 kHz
Polarization	linear, > 100:1 extinction	
Optical output	FC/APC connector or collimator with mounting flange (optional)	collimator & isolator node ⁶⁾
Output fiber length	up to 5 m	up to 3 m
Collimated beam diameter	0.9 ± 0.1 mm	
Beam height	NA	38 mm
Beam quality	$M^2 < 1.1$	
Pulse train monitoring	photodiode output for oscillator train, TTL synch pulse for laser output (when pulse picker included)	
Dimensions of collimator (D × L)	$\varnothing 33 \times 11.76$ mm	
Control interface	CAN (USB, RS232, LAN optional)	
Power supply (AC/DC adapter included)	100–240 V, 50–60 Hz AC	
Power consumption	maximal 230 W (typical 60 W)	
Operating conditions	10–30 °C, humidity – not condensing	

¹⁾ Due to continuous improvement all specifications are subject to change without notice.

²⁾ Other wavelengths available on request.

³⁾ Custom spectral bandwidth and pulse duration on request.

⁴⁾ Custom pulse repetition rates up to 70 MHz available, please inquire.

⁵⁾ Pulse picker is an option for FPS100 model. It supports external gating. FPS200 includes internal pulse picker.

⁶⁾ FPS200 model is provided with collimator & isolator node with dimensions 138×66.6×52 mm.

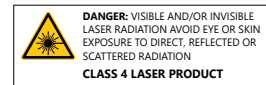

PERFORMANCE

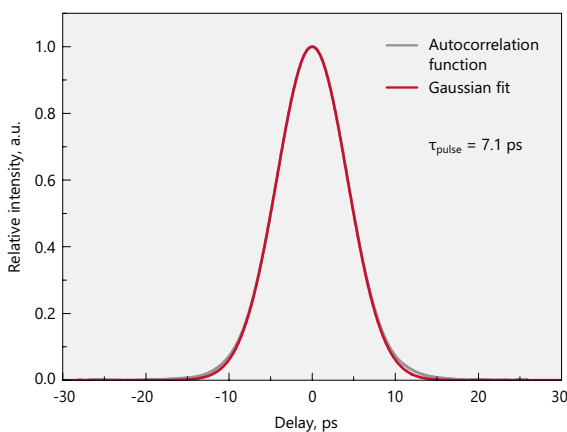

Typical autocorrelation curve of FPS100 laser

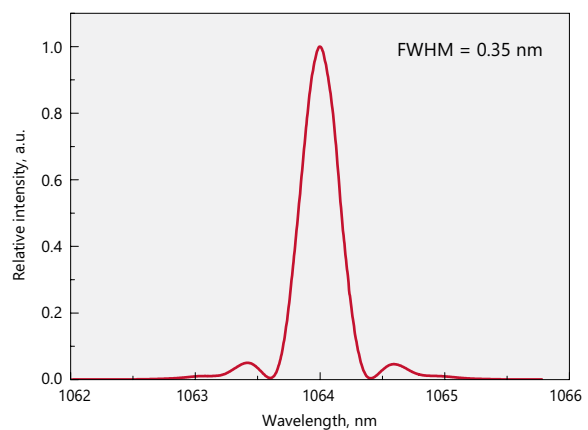

Typical spectrum from FPS100 laser

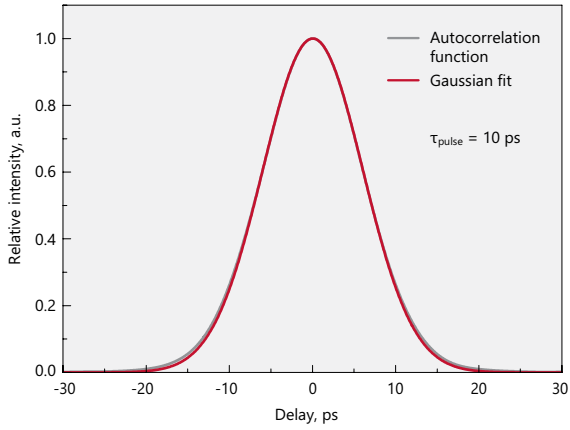

Typical autocorrelation curve of FPS200 laser

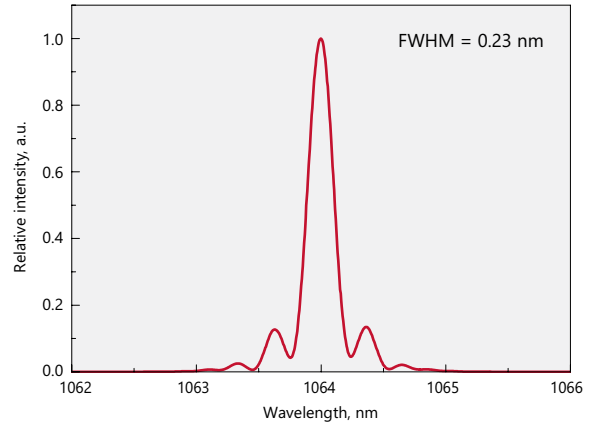

Typical spectrum from FPS200 laser

DRAWINGS

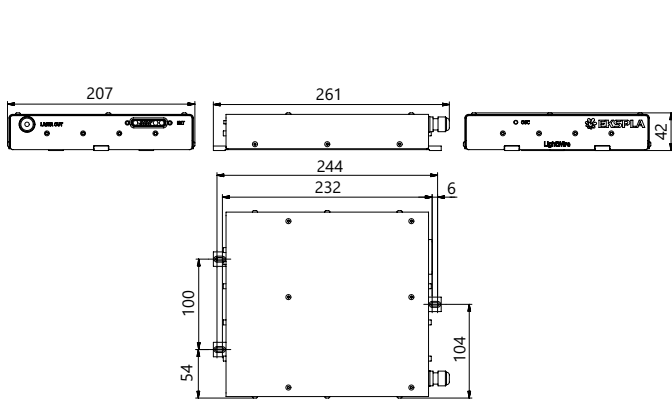

LightWire FPS series control unit outline drawing ("Flat" version)

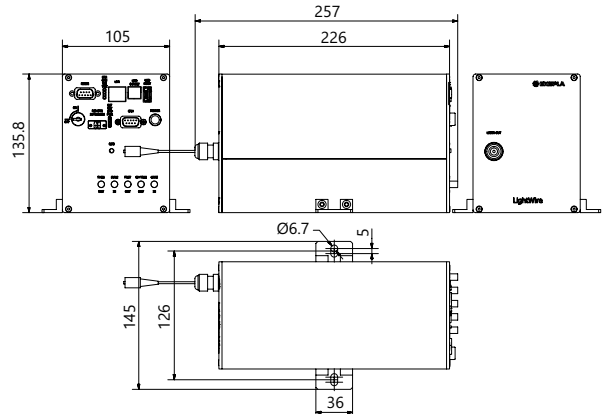

LightWire FPS series "Compact" version drawing. Example only. Actual dimensions depends on a selected laser configuration and options. Please enquire

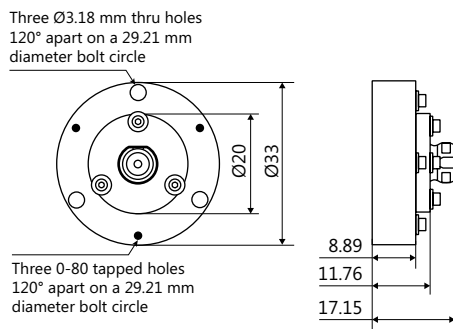

LightWire FPS100 laser collimator flange outline drawing for beam diameters 0.9 mm

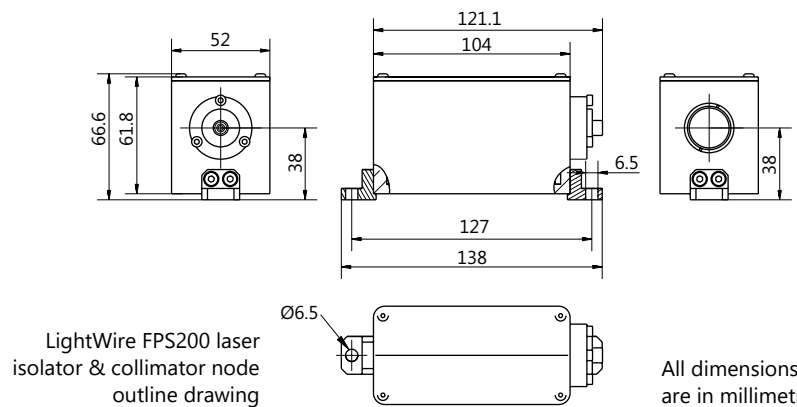

LightWire FPS200 laser isolator & collimator node outline drawing

All dimensions are in millimetres.