

Fiber-coupled THz Emitter and Detector

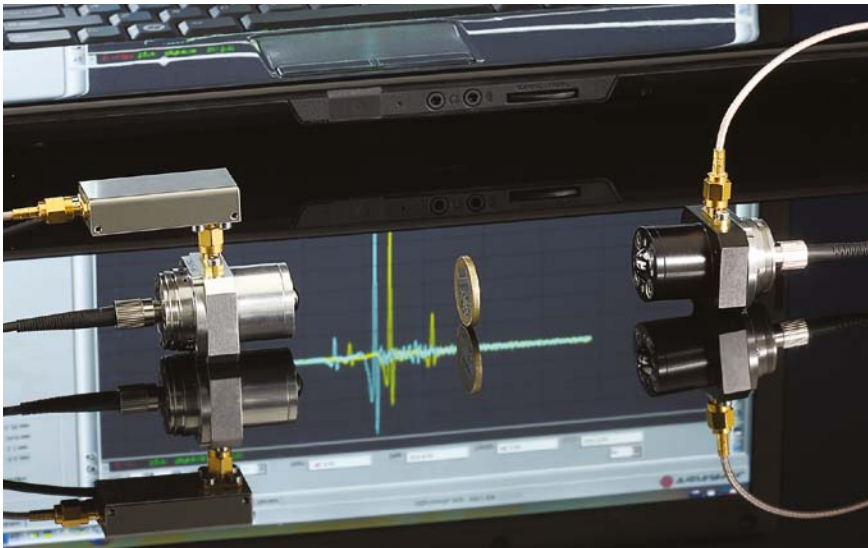

Fiber-coupled THz emitters and detectors offered by EKSPLA are designed for broadband operation and can be used in standard time-domain (THz-TDS) setup (Fig. 1).

housing compatible with standard 1" optical holders. Performance of each device is checked and technical passport, including testing report, is provided for customer.

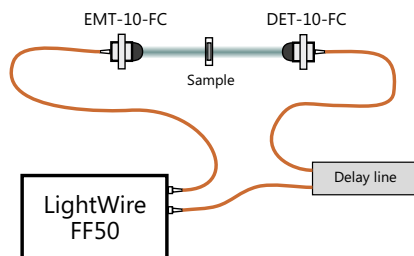

Fig. 1. THz time-domain spectroscopy setup

Unique GaBiAs material used in photoconductive antennas (PCA) features excellent sensitivity for wavelengths up to approx. 1060 nm and electron lifetime shorter than 1 ps. As a result ultra short half-cycle THz pulses with broad spectra up to 4 THz can be generated and detected. Pump beam fiber delivery eliminates time-consuming adjustments and ensures maximum flexibility of experiment. As an example, this feature allows fast and convenient switching between different geometries: transmission, reflection, etc. THz emitters and detectors are mounted into compact

INTEGRATED SILICON LENS

THz emitters and detectors are supplied with integrated hyper-hemispherical lenses, made from high-resistivity silicon, attached to PCA to increase the radiation efficiency of THz waves into free space. EKSPLA offers two standard types of these lenses: for collimated or diverging THz beam output. Advantage of collimated THz beam output is simple setup, because no additional optical components between THz emitter and detector are required for experiment. However, this design features bigger spherical aberrations of THz beam, which affects focusing. In second case design of lens assumes positioning of the PCA in aplanatic point, which significantly reduces spherical aberrations. As a result nearly diffraction limited spot of THz beam can be achieved.

FEATURES

- ▶ Based on unique GaBiAs photoconductive material
- ▶ Optimized for wavelengths around 1060 nm
- ▶ Technical passport and test report included

APPLICATIONS

- ▶ Time-resolved broadband THz spectroscopy
- ▶ Optical pump-THz probe spectroscopy
- ▶ Suitable for all-in-fiber system solution

PHOTOCONDUCTIVE ANTENNA (PCA)

Photoconductive antennas are particularly designed for THz emitter or THz detector. The substrate of GaAs contains mesa-etched epitaxial active layer of GaBiAs in order to achieve high dark resistance. High photosensitivity of the material allows use of low average power optical pulses for excitation. On its surface a coplanar Hertzian type dipole antenna structure is formed using AuGeNi metallization (Fig. 2). The gap between metallic contacts is similar to laser spot diameter in detector case and larger – in emitter case. Photoconductive chip is mounted on PCB and placed inside metallic housing of device. SMA sockets on back side of the housing are used to connect DC or AC bias to THz emitter or lock-in amplifier input to THz detector.

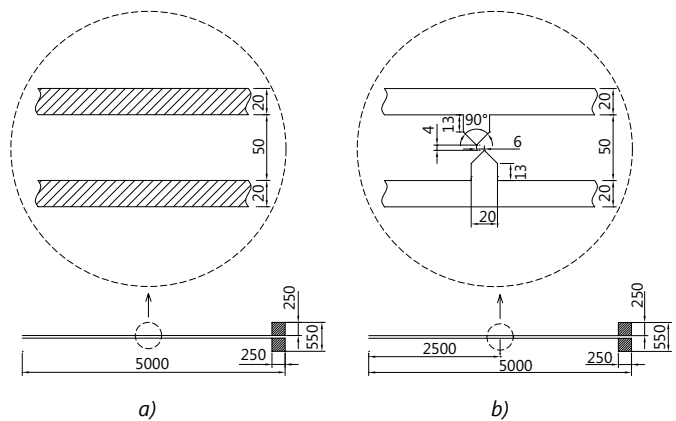

Fig. 2. Microstrip antenna drawings: (a) emitter, (b) detector (all dimensions are in micrometers)

SPECIFICATIONS

Model	Emitter EMT-10-FC	Detector DET-10-FC
PHOTOCONDUCTIVE ANTENNA		
Photoconductive material	GaBiAs	
Dimensions of the wafer	5 × 1.5 mm	
Thickness	600 μm	
Antenna type	strip line	dipole
Photosensitivity	up to 1100 nm	
Bias voltage	50 V max, 40 V typical	–
Detected THz bandwidth ¹⁾	–	>4 THz
INTEGRATED FOCUSING LENS		
Material	HRFZ-silicon	
Geometrical form	hyper-hemi-sphere	
THz beam output	collimated or diverging	–
FIBER DELIVERY		
Fiber length	3±0.2 m	
Fiber connector	FC/APC	
Wavelength ²⁾	1064 nm	
Maximum optical pulse energy (on fiber input)	1 nJ (30 mW at 30 MHz)	
Recommended pump source	EKSPLA LightWire FF50 (with double output option)	

¹⁾ Pumped by 130 fs, 20 mW, 30 MHz pulses.

²⁾ Other wavelengths are available on request.

ORDERING INFORMATION

Description	Model	Notes
Fiber-coupled THz emitter for 1060 nm wavelength	EMT-10-FC	Includes Si lens, optical fiber with FC/APC connector and coaxial cable with BNC connector
Fiber-coupled THz detector for 1060 nm wavelength	DET-10-FC	Includes Si lens, optical fiber with FC/APC connector and coaxial cable with BNC connector

FIBER DELIVERY

Standard configuration requires pre-chirped pulse with 0.5–2 ps duration on fiber input. Typically such pulse parameters are available directly from fiber lasers before compressor stage. In this case pulse is compressed while propagating through optical fiber with negative dispersion. Another solution can be applied for femtosecond pulses – near zero dispersion optical fiber. In such fiber femtosecond pulse keeps its form and pulse duration doesn't differ much on input and output of fiber. In both cases it works only for particular wavelength, so it should be specified while ordering. Laser radiation is delivered through FC/PCA fiber connector. It is focused onto PCA using lenses fixed inside the housing of THz emitter and THz detector.